

CUSTOMER _____

CUSTOMER'S P/N _____

DESCRIPTION _____ POWER INDUCTOR _____

SGTE PART NO. _____ GPDB1009-100M _____

SAMPLE NO.: S14081201 REVISION NO. A DATE 2014-8-12

SPECIFICATION FOR APPROVAL

FULLY APPROVED	REVISE APPROVED

SGTE 感通科技

深圳感通科技有限公司 (大陸工廠)

GANTONG TECHNOLOGY (SHENZHEN) CO., LTD.

深圳市平湖街道平湖村萬福路 26 號

No.26 Wan fu Road, Ping hu Village. Ping hu town, Shenzhen City.

Tel: 0755-28457600

Fax: 0755-28452952

感通科技有限公司 (台灣辦事處)

臺北縣汐止市新台 5 路一段 77 號 10 樓之 7

10F~7, N0.77, Sec.1, Hsin Tai 5 Road, Shi-chi City, Taipei.

Tel: 886-2-8698-2341

Fax: 886-2-8698-2342

納美科技股份有限公司 (香港辦事處)

LAPEE TECHNOLOGY LIMITED

香港九龍尖沙嘴加連威老道嘉蘭圍 5-11 號利時商業大廈 17 樓 1713 室

Room 1713 17/F, Rise Commercial Bldg5-11 Granville Cri cuit, Granville Rd, TSim Sha Tsui., Kln

Tel: 852-25301111

Fax: 852-25371111

<http://www.sgte.cn>

SPECIFICATION

RoHS
COMPLIANT

INDEX

COVER PAGE

■ SHAPE & DIMENSION.....	1-8
■ ELECTRICAL CHARACTERISTICS AND EXTERNAL TEST REPORT.....	2-8
■ ELECTRICAL CHARACTERISTICS.....	3-8
■ ELECTRICAL CHARACTERISTICS.....	4-8
■ ELECTRICAL CHARACTERISTICS.....	5-8
■ PACKING FOR SPECIFICATION.....	6-8
■ GENERAL CHARACTERISTICS.....	7-8
■ THE CONDITION OF REFLOW.....	8-8

APPROVED BY

CHECKED BY

DRAWING BY

Tianyi

8/12

Liu

8/12

Li

8/12

SPECIFICATION

**RoHS
COMPLIANT**

Customers Part Number	Item Name	Date
	Power Inductor	2014-8-12
Gan Tong Part NO.	Sample NO.	Page
GPDB1009-100M	S14081201	1-8

External Dimensions Unit (mm)

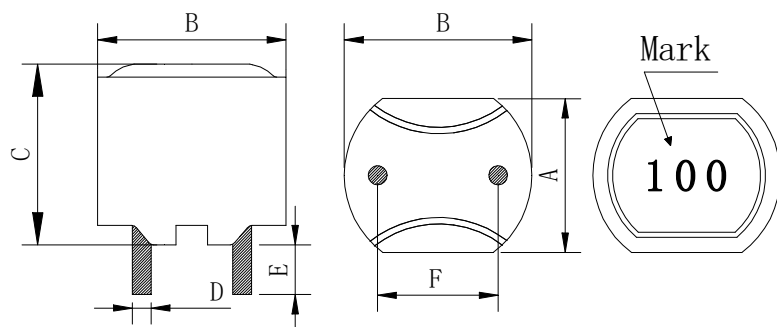

A	9.0± 0.5 (mm)
B	10.0± 0.5 (mm)
C	7.4± 0.5 (mm)
D	0.6± 0.1 (mm)
E	3.4± 0.5 (mm)
F	5.6± 0.5 (mm)
G	5.6± 0.5(mm)
H	1.0 (ref)

Coating:Black

Connection

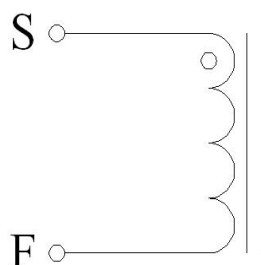

Recommended Land Pattern

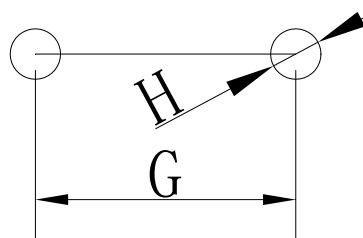

Electrical Specification

Measurement Item	Unit Tolerance	Specification	Test Frequency	Test Instrument
L	uH (±20%)	10uH ±20%	100KHz/0.1V	LCR Meter Agilent/4284A or Chroma /11300
DCR	mΩ	27.21mΩ Max		Chroma /16502
I rms	Amps	5A	100KHz/0.1V	LCR Meter Agilent/4284A+42841A
I sat	Amps	7A	100KHz/0.1V	or Chroma /11300+3302+1320+1320S

- I rms: Current that causes a 40°C temperature rise from 25°C ambient.
- I sat: DC current at which the inductance drops 35% from it's value without current.
- All test Data is referenced to 25°C ambient.
- Operating Temperature Range: -25°C to +125°C

TEST REPORT

**RoHS
COMPLIANT**

Customers Part Number	Item Name	Date	
	Power Inductor	2014-8-12	
Gan Tong Part NO.	Sample NO.	Revision No.	Page
GPDB1009-100M	S14081201	A	2-8

Electrical Characteristic

Item	L0A	DCR	I rms	I sat
Specification	10uH	27.21m Ω	5Amps	7Amps
Tolerance	$\pm 20\%$	Max	$\Delta T \leq 40^{\circ}\text{C}$	$L \geq 65\%$
1	9.97	17.89	7.8 $^{\circ}\text{C}$	81.8%
2	9.99	17.98		
3	9.67	17.87		
4	10.09	17.90		
5	9.69	17.67		
6	9.78	17.69		
7	10.02	17.74		
8	10.34	17.83		
9	10.44	17.81		
10	9.87	17.85		
\bar{X}	9.99	17.82		
σ	0.24	0.09		

External Dimensions

Item	A	B	C	D	E	F
Specification	9.0	10.0	6.5	0.6	3.4	5.6
Tolerance	± 0.5 (mm)	± 0.5 (mm)	Max (mm)	± 0.1 (mm)	± 0.5 (mm)	± 0.5 (mm)
1	9.09	10.03	6.43	0.57	3.52	5.83
2	9.07	10.07	6.38	0.56	3.49	5.79
3	9.05	10.03	6.39	0.59	3.57	5.71
4	9.03	10.06	6.41	0.60	3.62	5.75
5	9.09	10.06	6.44	0.58	3.60	5.80
6	9.06	10.02	6.36	0.57	3.72	5.82
7	9.07	10.05	6.42	0.61	3.57	5.78
8	9.06	10.03	6.37	0.59	3.46	5.81
9	9.05	10.00	6.39	0.63	3.51	5.79
10	9.08	10.03	6.41	0.61	3.58	5.77
\bar{X}	9.07	10.04	6.40	0.59	3.56	5.79
σ	0.02	0.02	0.02	0.02	0.07	0.03

Inductance measured at 100KHz/0.1Vrms.

Electrical specifications at 25 \pm 5 $^{\circ}\text{C}$. Humidity 60 \pm 10%

ELECTRICAL CHARACTERISTICS

**RoHS
COMPLIANT**

Customers Part Number	Item Name	Date
	Power Inductor	2014-8-12
Gan Tong Part NO.	Sample NO.	Page
GPDB1009-100M	S14081201	3-8

Inductance VS DC current

IDC	L	%LOA				
0A	9.96	100.0%				
1A	9.94	99.8%				
2A	9.76	98.0%				
3A	9.49	95.3%				
4A	9.18	92.2%				
5A	8.84	88.8%				
6A	8.51	85.4%				
7A	8.15	81.8%				
8A	7.81	78.4%				

CONDITION: 100KHZ/0.1V_{rms} AMBIENT: 20°C, 69.8%

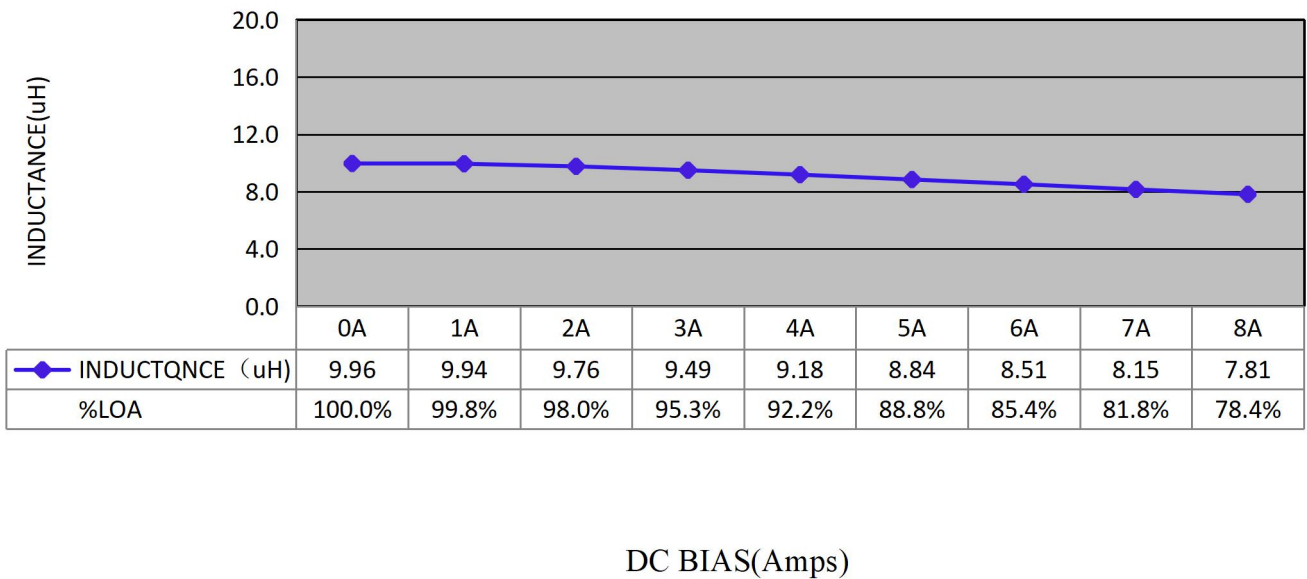

ELECTRICAL CHARACTERISTICS

RoHS
COMPLIANT

Customers Part Number	Item Name	Date
	Power Inductor	2014-8-12
Gan Tong Part NO.	Sample NO.	Page
GPDB1009-100M	S14081201	4-8

DC current VS Temperature

Time	L (μ H)	T ($^{\circ}$ C)	Δ T($^{\circ}$ C)			
0H	8.79	28.3				
0.5H	8.75	32.1	3.8			
1H	8.74	35.7	7.4			
2H	8.73	35.8	7.5			
3H	8.74	35.9	7.6			
4H	8.73	36.0	7.7			
5H	8.73	36.1	7.8			

CONDITION: Load 5A AMBIENT: 20 $^{\circ}$ C, 69.8%

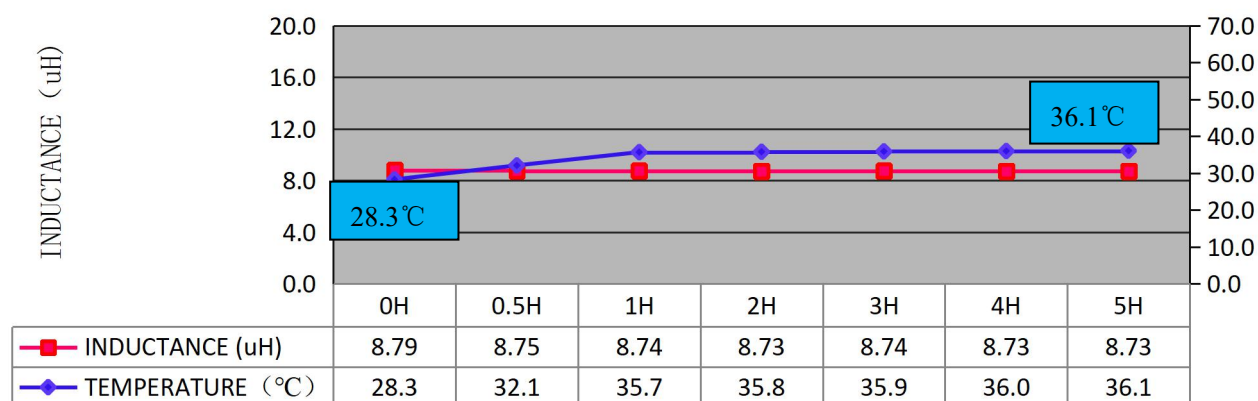

Inductance VS Temperature

ELECTRICAL CHARACTERISTICS

**RoHS
COMPLIANT**

Customers Part Number	Item Name	Date
	Power Inductor	2014-8-12
Gan Tong Part NO.	Sample NO.	Page
GPDB1009-100M	S14081201	5-8

Inductance VS Frequency

FREQ.	L (μH)					
1KHZ	10.13					
10KHZ	10.07					
100KHZ	9.94					
500KHZ	9.85					
800KHZ	9.87					
1000KHZ	9.90					

AMBIENT: 20°C, 69.8%

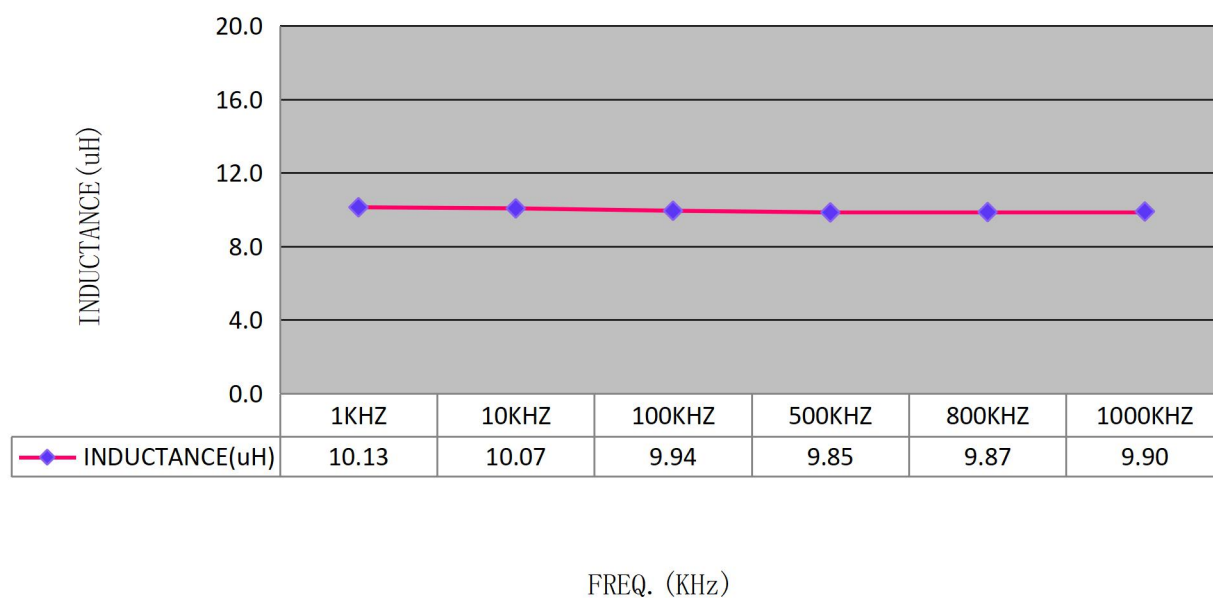

PACKING FOR SPECIFICATION

**RoHS
COMPLIANT**

Customers Part Number	Item Name	Date
	Power Inductor	2014-8-12
Gan Tong Part NO.	Sample NO.	Page
GPDB1009-100M	S14081201	6-8

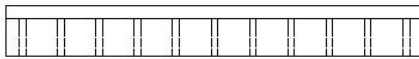
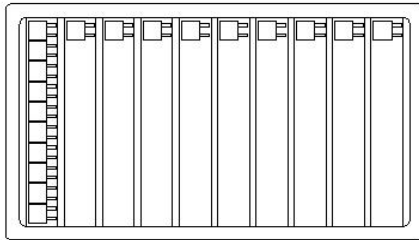

PET Size : 215*148 *16 (B) mm

Quantity : 130PCS/PET

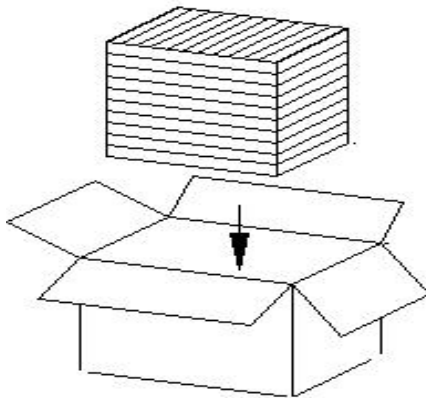

Small box Size : 238*156*165 mm

Quantity : 10PET/Small box

1Small box/1300PCS

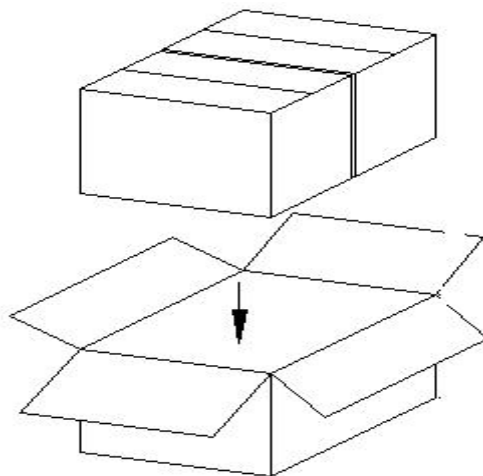

Big box Size : 328*251*175 mm

Quantity : 2 Small box/Big box

1 Big box/2600PCS

GENERAL CHARACTERISTICS

Gan Tong Part NO.: GPDB1009-100M

PAGE : 7-8

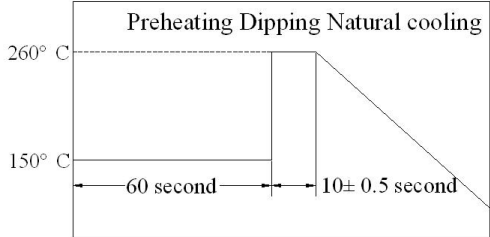
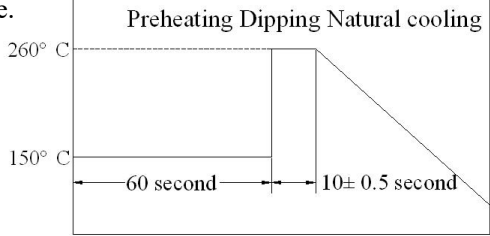
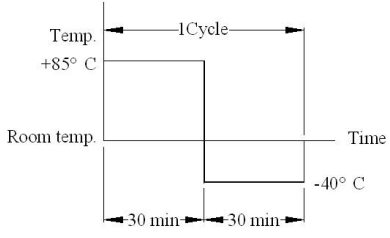
Item	Performance	Test Condition
Mechanical Performance Test		
Solder ability Test	More than 90% of terminal electrode should be covered with solder. After fluxing, component shall be dipped in a melted solder bath at $260\pm 5^{\circ}\text{C}$ for 10 seconds	
Solder Heat Resistance	Components should have not evidence of electrical and mechanical damage. Inductance: within $\pm 20\%$ of initial value. Preheat: 150°C 60 seconds Solder: (SnCu0.7) Solder Temperature: $260\pm 5^{\circ}\text{C}$ Flux: Rosin. Dip time: 10 ± 0.5 seconds	
Low temperature storage test	1. Appearance: No damage. 2. Inductance: within $\pm 20\%$ of initial value. 3. No disconnection or short circuit.	Temperature: $-40^{\circ}\text{C}\pm 5^{\circ}\text{C}$ Time: 500 ± 12 Hours Recovery: 4to24hrs of recovery under the standard condition after the removal from test chamber.
High temperature storage test		Temperature: $85^{\circ}\text{C}\pm 5^{\circ}\text{C}$ Time: 500 ± 2 Hours Recovery: 4to24hrs of recovery under the standard condition after the removal from test chamber.
Thermal Shock Test (Temperature cycle)		$-40\pm 5^{\circ}\text{C}$ for 30 Minutes. $+85\pm 5^{\circ}\text{C}$ for 30 Minutes. Total: 10 Cycles 
Humidity load life test		Temperature: $40\pm 5^{\circ}\text{C}$ Humidity: 90-95% Time: 500 ± 12 Hours Load: Allowed DC current Recovery: 4to24hrs of recovery under the standard condition after the removal from test chamber.

THE CONDITION OF REFLOW

RoHS
COMPLIANT

Gan Tong Part NO. : GPDB1009-100M

PAGE :

8-8

Wave Soldering

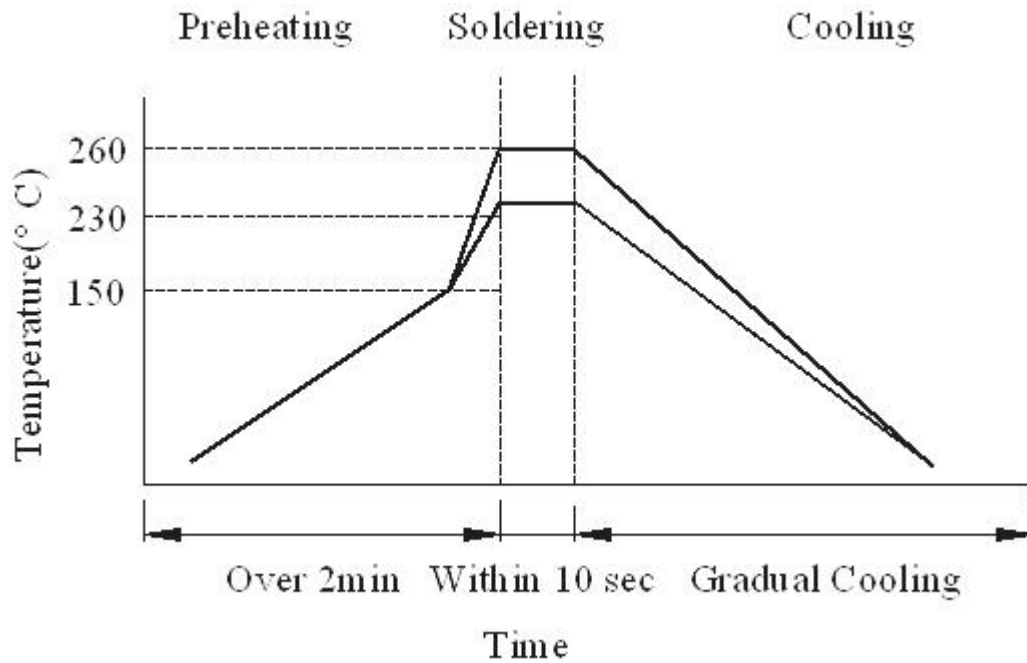

Hand soldering

