

客 户 :

Customer

客 户 料 号 :

Customer P/N

物 料 名 称 :

Item Name

感 通 型 号 : SPRH3D28-8R2M

GanTong P/N

承 认 书 编 号 : S24073055

Spec No.

版 本 号 : A0

Version No.

制 造 商 Manufacture	
拟 制 Prepared	汤四光
审 核 Checked	王 康
批 准 Approved	田 一
日 期 Date	2024/7/30

客 户 承 认 Approved by Customer	
批 准 Approved	
日 期 Date	

备 注:

Remark

1. 在使用产品前, 用户必须确认此产品是否适用于自身设计, 感通仅保证产品符合此份承认书的规格。

Before use, customer should confirm whether this product is suitable for their design, SGTE only ensure products meet this specification.

2. 本承认书的数据更改, 必须经双方确认, 任何一方单独修改无效。

This specification data change must be confirmed by both parties, any individual modification is in

3. 如客户未回签承认书即下订单, 则视为承认此份承认书。

If customer placed orders without signing back this specification, it is regarded as recognition.

1 外形尺寸(mm)
Appearance and dimensions

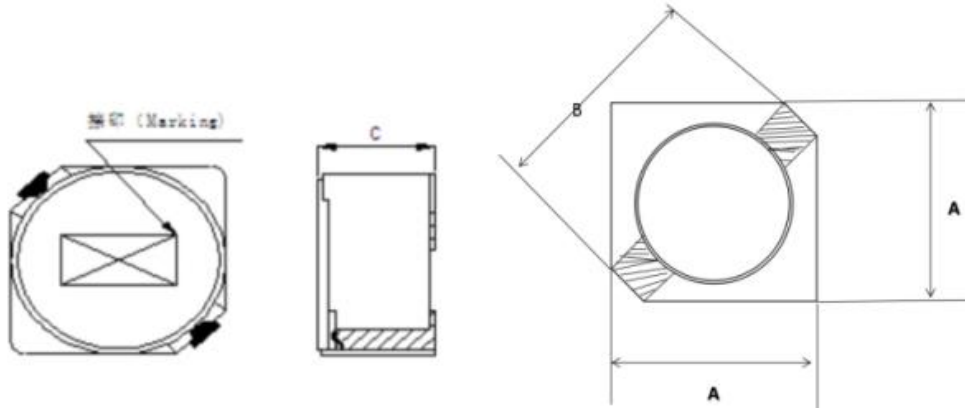

A	B	C
4.0Max.	5.2 Max.	3.0Max.

2 原理图
Schematic

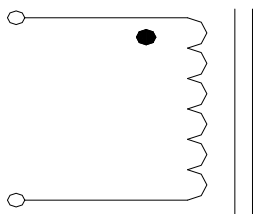

3 电气特性

Electrical characteristics

型号 Type No.	感值 L μH	直流电阻 DCR Ω	直流电流 IDC A
	±20%	Max.	Max.
SPRH3D28-8R2M	8.2	0.15	1.0

※1 电感值测试条件为100KHZ 0.25V.

Inductance is tested at 100KHZ 0.25V.

※2 特别提示：线路设计，组件布局，使用频率，散热系统等均会影响产品温度，请务必验证产品实际发热状况。

Special remind: Circuit design, component placement, frequency, cooling system and etc. all will affect the product temperature. Please verify the actual product temperature in the final application.

※3 所有数据基于环境温度25℃条件下测试。

All data is tested on 25℃ ambient temperature.

※4 工作温度范围：-40℃ ~ +125℃（包含产品发热）

Operating temperature range : -40℃ ~ +125℃ (Including self-temperature rise)

4 测试数据
Test data

ELECTRICAL TEST DATA					OREALL DIMENSTON (UNIT: mm)				Soldeyability
	L (uH)	DCR (Ω)	L1.00A - 0A*	IDC (A)	A	B	C	D	
SPD	8.2±20%	0.15 max	100% 70%	1.00 max	4.0Max	5.2	3.0Max	/	98%
1	8.1	0.110		OK	4.0	5.0	2.6	/	OK
2	8.3	0.109		OK	4.0	4.9	2.6	/	OK
3	8.2	0.108		OK	4.0	5.0	2.6	/	OK
4	8.4	0.109		OK	4.0	4.9	2.6	/	OK
5	8.2	0.109		OK	4.0	5.0	2.6	/	OK
6	8.6	0.109		OK	4.0	4.9	2.6	/	OK
7	8.6	0.108		OK	4.0	5.0	2.6	/	OK
8	8.2	0.108		OK	4.0	4.9	2.6	/	OK
9	8.8	0.107		OK	4.0	5.0	2.6	/	OK
10	8.2	0.108		OK	4.0	4.9	2.6	/	OK
×									
R									

5 包装规格 (Dimensions in mm)

Packaging specification

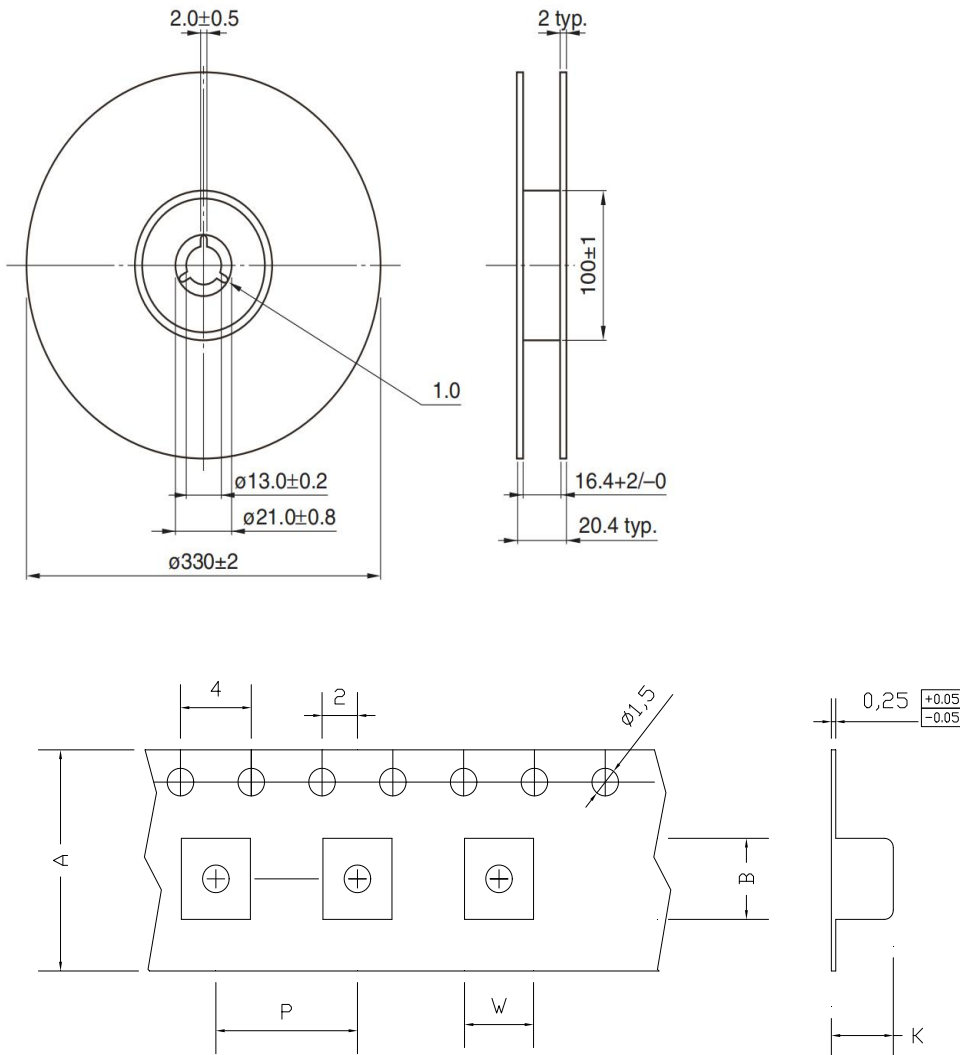

A	B	P	K	W
12±0.3	4.2±0.2	8.0±0.2	2.0±0.2	4.2±0.2

6 注意事项 Notes

- 6.1 产品最佳安装保质期限：12个月(从制造日期开始计算)
保存条件：密封包装，温度 $\leq 40^{\circ}\text{C}$ ，相对湿度 $\leq 70\%$ 。
The best assembly quality guarantee period of product : 12 months (From manufacture date),
Storage condition : seal in packaging, temperature $\leq 40^{\circ}\text{C}$, RH $\leq 70\%$.
- 6.2 如果取出使用，剩余产品请用胶袋密封，按照以上条件保存，避免电极氧化，影响焊接状态。
If taking out for use, the remaining products should be sealed in plastic bags and preserved
in accordance with the above conditions, to avoid oxidation of electrodes and affect soldering status.
- 6.3 请不要将产品保存于高温、高湿、有尘埃、腐蚀性气体的不适合环境中。
Do not keep products in unsuitable storage conditions,
such as areas susceptible to high temperature, high humidity, dust or corrosion.
- 6.4 请小心轻放，避免由于产品跌落或取出不当导致产品损坏。
Always handle products with care to avoid damage.
- 6.5 手上的油脂会导致产品的可焊性降低，请避免直接用手接触产品的端子，以保证最佳的可焊性。
Do not touch electrodes with bare hands directly, as oil secretions may inhibit soldering.
Always ensure optimum conditions for soldering.
- 6.6 当本产品应用到相似或新的项目时，电性可能因使用条件的不同而与规格产生一定的出入。
When product will be used on a similar or new project to the original one,
sometimes it might be unable to satisfy the specification due to different condition of usage.
- 6.7 本产品无任何自我保护功能，请勿在过载、高温、高压等不正常条件下使用。
This product itself does not have any protective function in abnormal conditions,
such as overload, high temperature, high voltage and etc.
- 6.8 超规格的高电压绝缘测试会对本产品绝缘金属粉体造成损伤，从而缩短产品的使用寿命。
Hi-Pot test with higher voltage than spec value will damage insulation material and shorten its life.
- 6.9 如果将本产品用于埋置复合组件，有可能会对本产品表面造成腐蚀，请咨询本公司。
If using in potting compound, the product might be damaged, please consult with us.
- 6.10 请不要清洗本产品，如果需要清洗，请咨询本公司。
Please do not clean this product. If necessary, please consult with us.